

CONSIDERATIONS ON TEMPERATURE AND HEAT TRANSFER IN DENTAL IMPLANTS: AN EX VIVO STUDY

Razvan Curca¹, Crețu Cosmin - Ionuț¹, Tibeică Andreea¹, Stamatin Ovidiu¹, Oniciuc Cosmin¹, Adam Eduard¹, Budău Corina¹, Camilar Maria¹, Bolat Maria¹, Radu Iodan-Alexandru¹, Agop-Forna Doriana*², Andreea Didilescu³, Marina Imre³, Silviu Mirel Pituru³, Norina Consuela Forna¹

1 "Gr.T.Popa" U.M.Ph. - Iași, Romania, Faculty of Dentistry, Department of Implantology

2 "Gr.T.Popa" U.M.Ph. - Iași, Romania, Faculty of Dentistry, Department of Oral Surgery

3 „Carol Davila” University of Medicine, Faculty of Dentistry, Bucharest, Romania

*Corresponding author: Agop-Forna Doriana; e-mail dr.doriana.forna@gmail.com

All authors have the same contribution.

ABSTRACT

Teeth that have been replaced have significantly different thermal behavior than natural teeth due to the exceptional heat conductivity of the metals used for restorations, such as titanium or titanium alloy. **Aim of the study:** The current ex vivo investigation sets out to quantify temperature shifts in implant. We postulated that titanium dental implants could attain dangerously high temperatures due to heat conduction and the subsequent transmission of heat to the surrounding bone. **Material And Method:** Building a three-dimensional model was an integral part of the study with the help of Catia V5R19 program. We generated an assembly bone-implant-PMMA crown with all component elements of the complex exhibiting linear elasticity and isotropic properties of the same quality. We also conducted FEM analyses for the entire assembly, considering a range of values for temperature to which the whole complex was exposed. **Results:** As temperatures rise, the thermal flux affects the implant and the PMMA crown, with thermal deformations caused by expansion appearing as a result. **Conclusions:** When assessing the efficacy of metal dental implants, thermal stress must be considered.

Key words: dental implant, thermal stress, osseointegration

INTRODUCTION

Problems associated with tooth loss have troubled humans for ages, despite great advances in the detection, prevention, management, and treatment of oral-dental illnesses. The idea of using an implant to replace a lost tooth has been around for a long time. A variety of materials, such as ivory, bone, metals, and valuable stones, were first used to create an anatomical model of the actual tooth [1,2]. Dental implants are becoming more popular among patients of all ages who are looking to replace a single tooth, multiple teeth, or even all of them. When people get dental implants, their lives are transformed. They regain the comfort and self-assurance to chew, eat, speak, smile, laugh, socialize, and enjoy life in general. This greatly improves their quality of life [3,4]. One of the most distinctive aspects of food flavor is the sensation of temperature.

Thermal stimulation of the oral mucosa can affect the emotional and sensory aspects of food stimuli in humans [5,6] and the perceived strength of specific flavor characteristics [7,8]. Other sources of phantom flavors include tongue thermal stimuli [9]. While research into tasting and other flavor modalities has advanced, our knowledge of how brain activity represents oral temperature sensed alone contributes to ingestive preference has remained stagnant.

Every single day, teeth undergo thermal loading from the constant contact with hot food and drink. The pulp, dentin, and enamel all play a role in the conduction of heat from variations in intraoral temperature to the tooth surface. Enamel and dentin provide protection for the pulp from quick temperature changes because their thermal conductivity levels are lower [8].

Since metals like titanium or titanium alloy, which are commonly utilized in clinical restorative applications, are outstanding heat conductors, the thermal behavior of replaced teeth differs greatly from that of intact teeth [10,11]. Consuming foods and drinks that are exceedingly hot on a regular basis can influence the efficacy of implant treatment methods, and high temperatures can harm tissues and organs irreparably [12].

Successful rehabilitative and restorative therapy requires mechanically stable dental implants. It can be said that osseointegration around the implant is the bedrock of dental implant therapy, thus playing a vital role in ensuring the desired stability.

The current *ex vivo* investigation sets out to quantify temperature shifts in implant. We postulated that titanium dental implants could attain dangerously high temperatures due to heat conduction and the subsequent transmission of heat to the surrounding bone.

MATERIALS AND METHODS

Dental implants can only be a success if the bone is healthy, and the implant location is prepared correctly. Research has linked factors like cigarette use to clustering of dental implant failure patterns within participants [13]. The importance of minimizing mechanical and thermal stress on the bone during the preparation of the implant site has recently been acknowledged [13–15]. Uncontrolled drilling or acrylic polymerization near an implant abutment can cause heat-induced bone injury, according to prior research.

However, temperature variations surrounding implants during normal oral functions have not been studied.

Thermal exposure, which includes both the duration and the temperature, is the determinant of thermal damage [16]. There have been reports of hyperemia at 40°C. At 42°C, proteins such as procollagen and collagen I, which are essential in bone remodeling, denature [17]. Additionally, exposing cortical bone to 47°C for 1 minute produces necrosis.

Consumption of hot beverages could potentially lead to an increase in temperature along the implant, potentially harming the surrounding tissues, as metals like titanium or titanium alloy are great heat conductors.

Building a three-dimensional model was an integral part of the study with the help of Catia V5R19 program. Catia V5R19 is a state-of-the-art program that was first created in France to optimize prototype testing of mechanical assembly.

The design, modeling, and analysis capabilities in Catia V5R19 are extensive, and they make use of high-performance CAD, CAE, CAM, or PLM models to create models that are both valid and useful. We generated an assembly bone-implant-PMMA crown with all component elements of the complex exhibiting linear elasticity and isotropic properties of the same quality. After the dental implants and bone are computationally discretized, the mesh building procedure begins in order to create the FE model. Hexahedral and linear/quadratic tetrahedral elements have found use in the past for dental and bone implant applications, as seen in fig.1

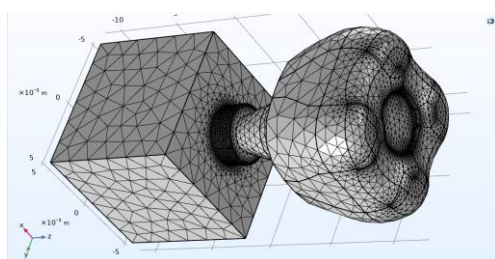

Fig.1. The discretized complex model

We have considered the load to be 0, meaning the entire assembly is not subjected to external forces. We also conducted FEM analyses for the entire assembly, considering a range of values for temperature to which the whole complex was exposed. Deformations occur (through expansions), a thermal flux (the crown supports a variable temperature, while the jaw has 37 °C. The reference temperature (against which reporting is done, and calculations are also carried out) is 20 °C, that is, the ambient temperature.

RESULTS

In the following we present the results from the analyses made for different temperatures: 258⁰K (-15⁰C), 313⁰K (40⁰C), 353⁰K (80⁰C).

In figure 2 we can notice temperature map at 258⁰K (-15 °C) on the tooth. It is observed that the implant practically does not cool down. For figure 3 and 4 It is observed that the thermal flux changes, compared to fig. 2, the entire complex becoming warmer.

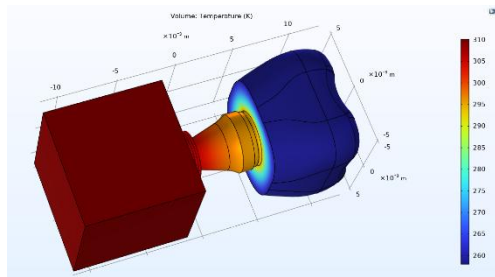

Fig.2. The map for 285⁰K

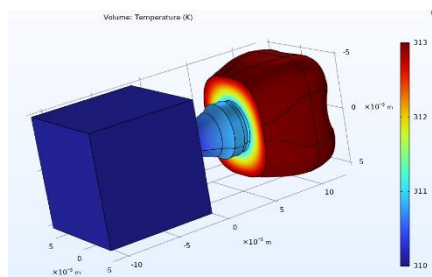

Fig.3. The map for 313⁰K

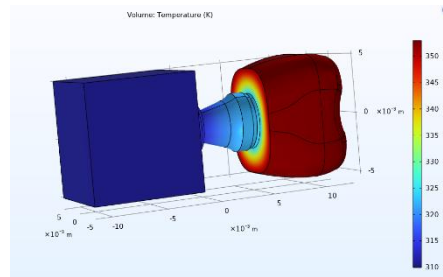

Fig.4. The map for 355⁰K

In figure 5 we have the displacements caused by expansions. The jaw does not move. Instead, the tooth displacement reaches 0.012 mm, so reduced deformation. In fig. 6, compared to fig. 5, it is observed that the displacements are smaller, with the exception of the PMMA crown. The maximum value is still 0.012 mm. In the meantime, in fig. 7 displacements are distributed as in the previous situations, but this time they reach 0.03 mm (about 3 times larger). Practically only the PMMA crown is affected.

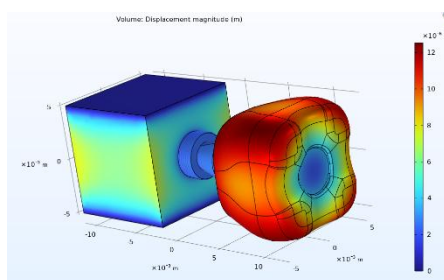

Fig.5. The displacements for 285⁰K

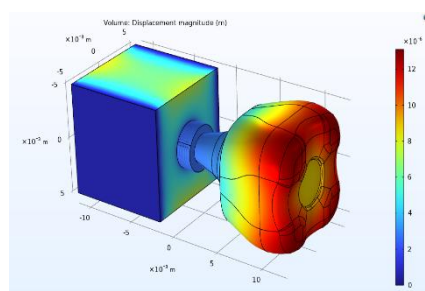

Fig.6. The displacements for 313⁰K

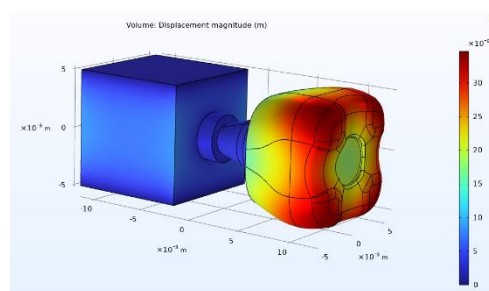

Fig.7. The displacements for 355⁰K

In fig. 8 we can see Von Mises stresses on the assembly with maximum visible values of 50-60 MPa. In fig.9 Von Mises stresses occur in the same areas but are significantly lower while, in fig. 10 the von Mises stresses in the assembly highlight the same stressed area as in the previous cases, but the maximum values decrease to a maximum of 25 MPa.

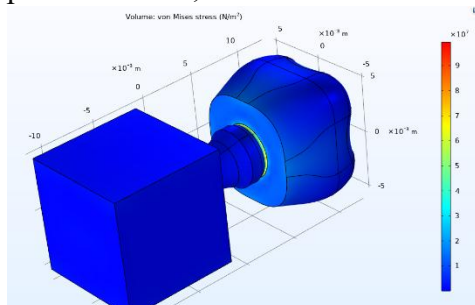

Fig.8 Von Mises stresses for 285⁰K

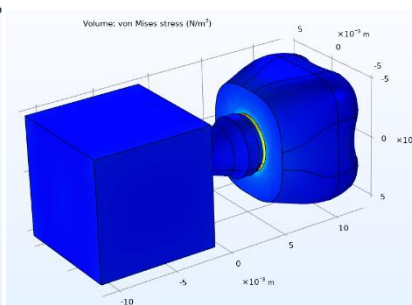

Fig.9 Von Mises stresses for 313⁰K

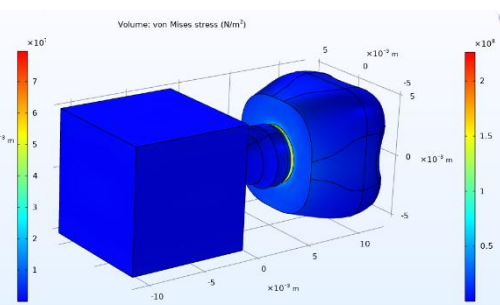

Fig.10 Von Mises stresses for 355⁰K

In figure 11 we have Von Mises stresses on the crown. It is observed that, due to expansions, the highest stresses (20, 25 MPa) occur at the level of the contact between the crown and its abutment, in the lower area. In fig.12 the stressed areas remain, but the maximum values do not exceed 20 MPa and in fig.13 stresses on the crown, with higher values, up to 60 MPa.

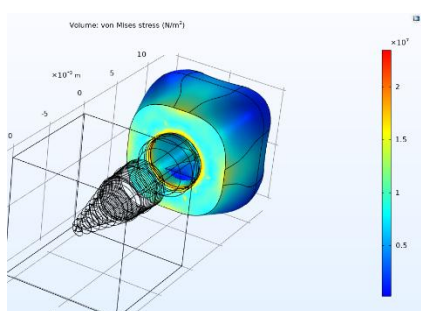

Fig.11 Von Mises stresses on PMMA for 285⁰K

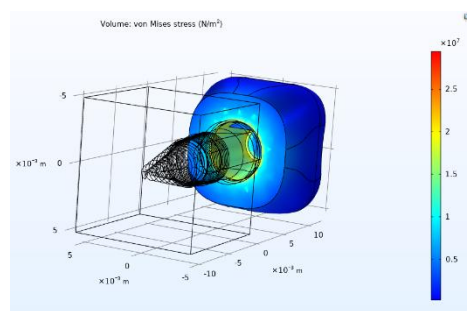

Fig.12 Von Mises stresses on PMMA for 313⁰K

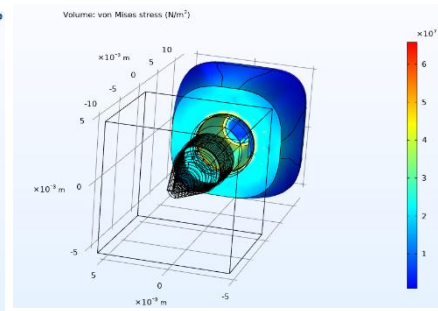

Fig.13 Von Mises stresses on PMMA for 355⁰K

The graph in figure 14, suggests the evolution of deformations with temperature, almost linear evolution is observed, with a more pronounced increase after the tooth temperature of 40⁰ C.

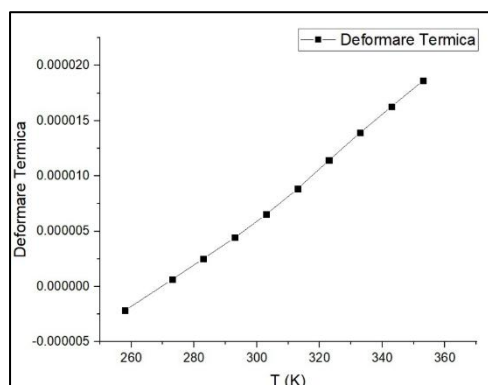

Fig.14 Thermal deformation

Along with the temperature variations, we also calculated the variations of the Poisson's ratio, the Von Mises forces exerted on the PMMA crown, and Young's modulus, illustrating them in the graphs below.

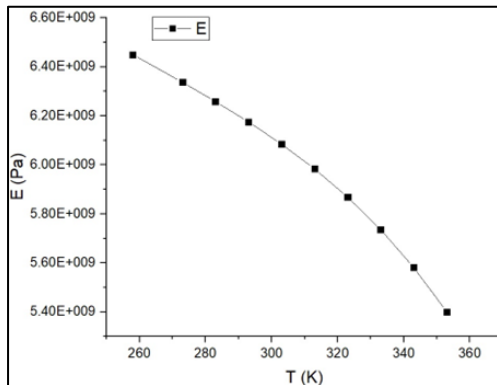

Fig.15 Young's modulus with temperature

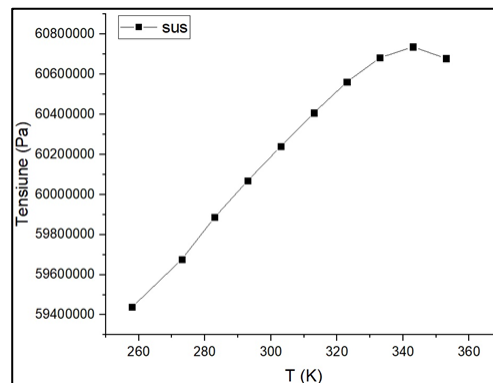

Fig.16 von Mises stress on the crown

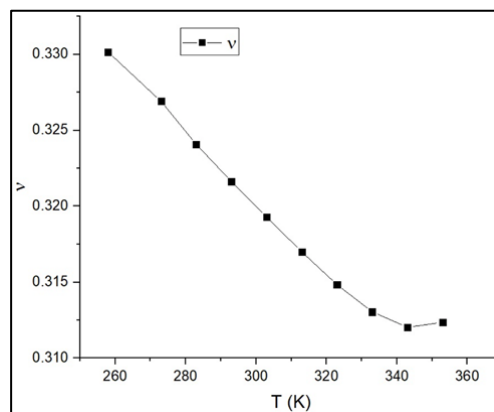

Fig.17 Poisson's contraction coefficient

DISCUSSION

Because of their tight connection in the mouth, the abutment and implant are considered as a single unit for thermal conductivity purposes. The same temperatures seen at the abutment and inside the implant cavity could be due to the transmission of hot fluids from the oral cavity through the little gap between them. In their theoretical computer model, Wong et al. [18] proposed that when the implant head is heated to 60–70°C, a 47°C temperature front might form at a distance of 3–4.5 mm along the implant.

The oral cavity temperature can rise to 67°C [16] and even 76°C to 77°C after drinking hot beverages, according to previous research [19,20]. In an ex vivo

model of a bovine jaw with an implant, the highest temperatures recorded at the implant-bone interfaces were higher than the temperature threshold for transitory changes in bone, which is 42°C [19]. The importance of minimizing mechanical and thermal stress on the bone during the preparation of the implant site has recently been acknowledged.

CONCLUSIONS

When it comes to dental implant therapy, osseointegration is crucial. Although dental implants are a dependable and preferred method of treating patients who are missing teeth, there are some risks associated with using them, such as irreparable harm to

nearby tissues and organs and unfavorable results and sequelae.

Our results suggest that drinking very hot beverages on a regular basis may contribute to clustering implant failures. Although there is a lack of evidence about the effects of prolonged exposure to temperatures higher than 40°C or even 80°C on the interface between osseointegrated implants and bone, patients may be advised of the possibility of such damage. More research

is needed to establish the risk of implant failure associated with patients' habitual consumption of extremely hot beverages, which they rarely mention.

When assessing the efficacy of metal dental implants, thermal stress must be considered.

CONFLICT OF INTEREST AND FUNDING

The authors declare that there is no conflict of interest, and they received no funding.

REFERENCES:

1. Bassir SH, El Kholy K, Chen CY, Lee KH, Intini G. Outcome of early dental implant placement versus other dental implant placement protocols: A systematic review and meta-analysis. *J Periodontol*. 2019 May;90(5):493-506.
2. Kageyama I, Maeda S, Takezawa K. Importance of anatomy in dental implant surgery. *J Oral Biosci*. 2021 Jun;63(2):142-152.
3. Duong HY, Rocuzzo A, Stähli A, Salvi GE, Lang NP, Sculean A. Oral health-related quality of life of patients rehabilitated with fixed and removable implant-supported dental prostheses. *Periodontol 2000*. 2022 Feb;88(1):201-237.
4. Gonçalves GSY, de Magalhães KMF, Rocha EP, Dos Santos PH, Assunção WG. Oral health-related quality of life and satisfaction in edentulous patients rehabilitated with implant-supported full dentures all-on-four concept: a systematic review. *Clin Oral Investig*. 2022 Jan;26(1):83-94.
5. Lemon CH, Kang Y, Li J. Separate functions for responses to oral temperature in thermogustatory and trigeminal neurons. *Chem Senses*. 2016 Jun;41(5):457-71.
6. Lemon CH. Modulation of taste processing by temperature. *Am J Physiol Regul Integr Comp Physiol*. 2017 Oct 1;313(4):R305-R321.
7. Chapko MJ, Seo HS. Characterizing product temperature-dependent sensory perception of brewed coffee beverages: Descriptive sensory analysis. *Food Res Int*. 2019 Jul; 121:612-621.
8. Nachtigal D, Andrew K, Green BG. Selective Effects of Temperature on the Sensory Irritation but not Taste of NaCl and Citric Acid. *Chem Senses*. 2019 Jan 1;44(1):61-68.
9. Patel Z, Geerts GA. Temperature changes along a dental implant. *Int J Prosthodont*. 2011 Jan-Feb;24(1):58-63.
10. Ormianer Z, Feuerstein O, Assad R, Samet N, Weiss EI. In vivo changes in dental implant temperatures during hot beverage intake: a pilot study. *Implant Dent*. 2009 Feb;18(1):38-45.
11. Wong K, Boyde A, Howell PG. A model of temperature transients in dental implants. *Biomaterials*. 2001 Oct;22(20):2795-7.
12. Yeo IS, Lee JH, Kang TJ, Kim SK, Heo SJ, Koak JY, Park JM, Lee SY. The effect of abutment screw length on screw loosening in dental implants with external abutment connections after thermocycling. *Int J Oral Maxillofac Implants*. 2014 Jan-Feb;29(1):59-62.
13. Borchering K, Schmidmaier G, Hofmann GO, Wildemann B. The rationale behind implant coatings to promote osteointegration, bone healing or regeneration. *Injury*. 2021 Jun;52 Suppl 2: S106-S111.
14. Değer Y, Adigüzel Ö, Yiğit Özer S, Kaya S, Seyfioğlu Polat Z, Bozyel B. Evaluation of Temperature and Stress Distribution on 2 Different Post Systems Using 3-Dimensional Finite Element Analysis. *Med Sci Monit*. 2015 Nov 29; 21:3716-172.
15. Dupont N, Koenig V, Vanheusden A, Mainjot A. Echecs des prothèses dentaires et implantairens en zircone : le point sur les facteurs de risqué . *Rev Med Liege*. 2014;69 Spec No:66-71.

16. Dewhirst MW, Viglianti BL, Lora-Michiels M, Hanson M, Hoopes PJ. Basic principles of thermal dosimetry and thermal thresholds for tissue damage from hyperthermia. *Int J Hyperthermia*. 2003 May-Jun;19(3):267-94.
17. Laurito D, Lamazza L, Garreffa G, De Biase A. An alternative method to record rising temperatures during dental implant site preparation: a preliminary study using bovine bone. *Ann Ist Super Sanita*. 2010;46(4):405-10.
18. Feuerstein O, Zeichner K, Imbari C, et al. Temperature changes in dental implants following exposure to hot substances in an ex vivo model. *Clin Oral Impl Res*. 2008; 19:629-633.
19. Barclay CW, Spence D, Laird WRE. Intra-oral temperatures during function. *J Oral Rehabil*. 2005; 32:886-894.